

Review

Cooling Strategies for Photovoltaic Modules in High-Temperature Tropical Environments: A Review

M. K. Adam^{1*}, A.B. Muhammad², V. M. Dagala², U.A. Mukhtar²

¹Advanced Manufacturing Technology Development Institute, Jalingo, Taraba State, Nigeria.

²Department of Mechanical Engineering, University of Maiduguri, Nigeria.

Correspondence should be addressed to: kachallaadam44@gmail.com

Abstract: Photovoltaic (PV) module performance is significantly constrained by operating temperature rise, particularly in hot and tropical climates where a large portion of incident solar radiation is converted into heat rather than electricity. Experimental and review studies report that PV module temperatures commonly reach 50–60 °C and may approach 80 °C under high ambient conditions, resulting in a power reduction of approximately 0.4–0.5% per °C increase above standard test conditions. This performance degradation is primarily due to temperature-induced reduction in open-circuit voltage and is further associated with accelerated material aging and reliability losses. To address thermal losses, research has increasingly focused on passive and low-energy cooling strategies. These include rear-mounted heat sinks and fins that enhance natural convection, air channels and chimney-based designs that promote buoyancy-driven airflow, and phase change material (PCM) systems that absorb excess heat through latent thermal storage. Recent studies emphasize thermal conductivity enhancement of PCM using fins, metal foams, or structured containers, achieving PV temperature reductions exceeding 20 °C and corresponding efficiency improvements. Water-assisted backside cooling and hybrid systems combining air, conduction, and water mechanisms have also demonstrated short-term gains in electrical output under high solar irradiance. Despite notable progress, key research gaps persist, including the absence of standardized net-energy evaluation frameworks, limited long-term field data linking cooling to degradation reduction, challenges in PCM discharge under hot night conditions, water sustainability concerns, and insufficient emphasis on scalable, low-cost, and retrofit-compatible designs. Addressing these gaps is critical for reliable PV operation in high-temperature environments.

Keywords: Photovoltaic modules; passive cooling; tropical climates; CFD modeling

1.0 INTRODUCTION

Solar energy plays a vital role in energy structure adjustment and long-term sustainability due to its abundant availability, flexible applications, and minimal environmental pollution (Harmailil et al., 2024). Solar energy technologies also support sustainable communities and contribute to socioeconomic development. Several forms of solar energy utilization have been developed, including solar thermal power, solar photovoltaic (PV) power, solar-powered hydrogen generation, solar desalination, and solar heat supply. Among these technologies, photovoltaic power remains the most widely adopted solar energy application (Ahmad et al., 2021).

Photovoltaic (PV) technology harnesses solar energy using semiconductor materials that exploit the photovoltaic effect to convert solar radiation directly into electrical energy (Bijjargi et al., 2016). PV modules are typically rated under standard test conditions (STC), which assume a cell temperature of 25 °C, solar irradiance of 1000 W/m², and an air mass of 1.5. However, actual outdoor operating conditions often deviate significantly from these controlled laboratory conditions. Consequently, environmental parameters such as temperature, humidity, dust accumulation, wind speed, and solar intensity strongly influence PV system performance and durability (Harmailil et al., 2024). With continuous advancements in PV technology, global installed PV capacity has increased steadily over the years. A conventional PV module consists of multiple layers, including a glass cover, ethylene-vinyl acetate (EVA) encapsulation, photovoltaic cells, a secondary EVA layer, and a back sheet made from materials such as Tedlar, all enclosed within an aluminum frame (Ahmad et al., 2021). Figure 1 illustrates the layers of a PV module.

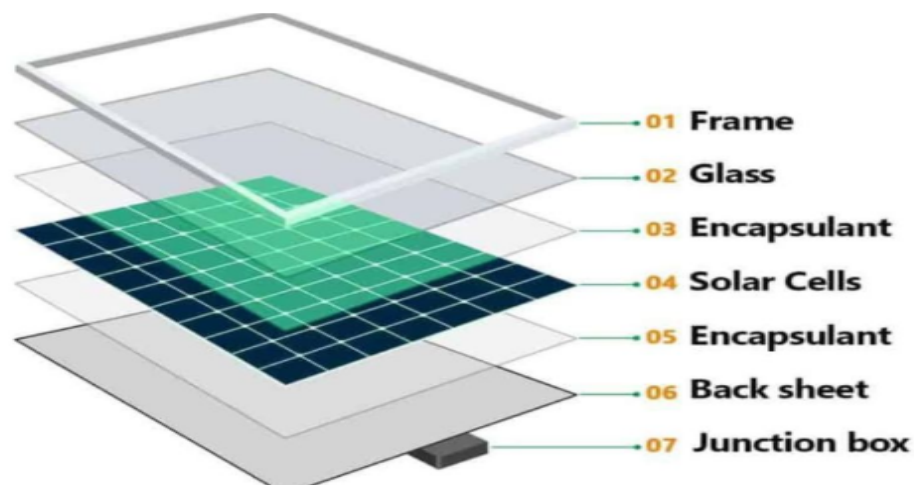

Figure 1: Structural Morphology of a PV Panel

PV TECHNOLOGY

Photovoltaic (PV) technology converts sunlight directly into electrical power using semiconductor materials, making it one of the most practical and widely adopted renewable energy technologies (Ahmad et al., 2021). The fundamental principle underlying PV operation is the photoelectric effect, first discovered by the French physicist Edmond Becquerel in 1839, who observed that certain materials generate electrical current when exposed to sunlight (Harmailil et al., 2024).

Over time, advancements in material science and semiconductor engineering have led to the development of modern photovoltaic cells with improved efficiency and durability. When sunlight strikes the surface of a silicon-based PV cell, photons transfer energy to electrons, causing them to break free from their atomic bonds and create electron-hole pairs. As shown in Figure 2, the free electrons migrate toward the n-type semiconductor layer, while the holes move toward the p-type layer, generating an electric potential difference across the junction (Bijjargi et al., 2016). As long as there is solar radiation, this process continues, and when an external circuit is connected, electrons flow through the circuit to produce an electric current (Ahmad et al., 2021).

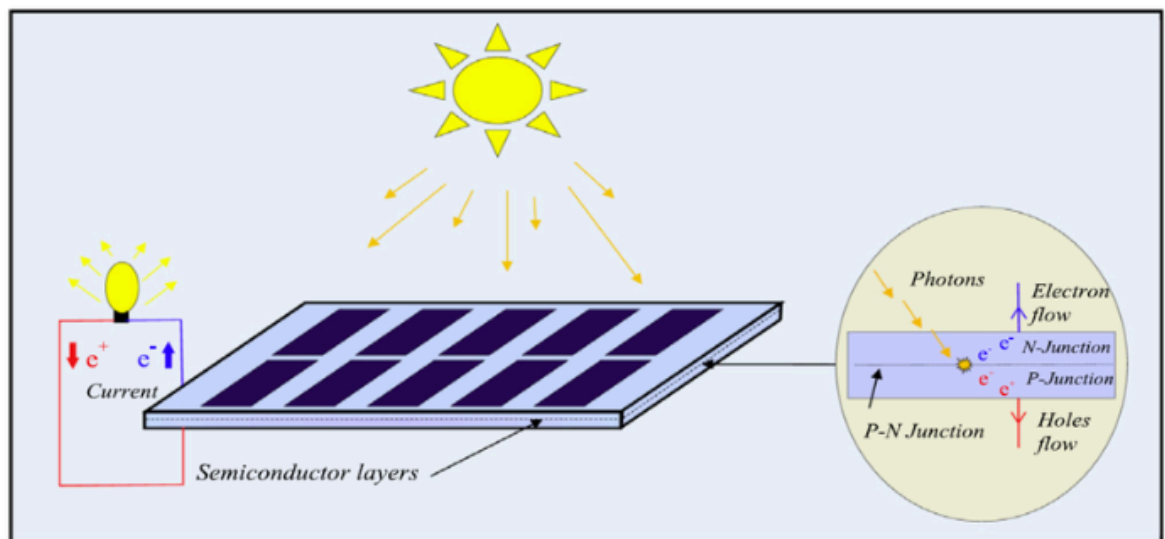

Figure 2: Photoelectric phenomena

Recent technological progress has established PV systems as a reliable and environmentally friendly energy source with key advantages such as reduced greenhouse gas emissions, scalability, adaptability to various installation conditions, and long operational lifespans. However, PV performance remains strongly influenced by several

environmental and operational factors, including dust accumulation, panel orientation, inclination angle, shading, solar irradiance, and especially operating temperature. Elevated temperatures adversely affect PV conversion efficiency, making thermal management a critical consideration in PV system design and deployment (Harmailil et al., 2024).

Recent years have witnessed significant advancements in photovoltaic (PV) technology, establishing it as a widely recognized renewable energy source with notable advantages such as reduced carbon dioxide emissions, short payback periods, adaptability to diverse installation conditions, and durability under harsh environments (Harmailil et al., 2024). Despite these advantages, PV systems are influenced by several performance-limiting factors. Variables such as dust accumulation, surface reflection losses, tilt angle variation, module orientation, shading effects, solar radiation intensity, and operating temperature significantly affect energy conversion efficiency, often leading to reduced electrical output (Ahmad et al., 2021; Bijjargi et al., 2016). Among these factors, elevated operating temperature remains one of the most critical challenges, as it directly degrades PV conversion efficiency and long-term reliability (Harmailil et al., 2024).

Previous studies indicate that the theoretical photoelectric efficiency of single-crystalline silicon cells under standard test conditions can reach approximately 33.7%, while commercially available crystalline silicon PV modules typically exhibit efficiencies ranging from 12% to 18% (Bijjargi et al., 2016). An increase in PV module operating temperature leads to a reduction in open-circuit voltage and fill factor, resulting in increased charge carrier recombination and a decline in power output. It has been widely reported that for every 1 °C increase in PV module temperature, electrical efficiency decreases by approximately 0.4–0.65% (Ahmad et al., 2021; Harmailil et al., 2024). Environmental factors such as wind speed, solar irradiance, dust accumulation, and ambient humidity significantly influence PV module temperature during outdoor operation. Under high solar irradiance, PV modules can rapidly accumulate waste heat, further exacerbating efficiency losses. Therefore, effective thermal management strategies are essential to enhance PV electrical performance, reliability, and operational lifespan, particularly in high-temperature tropical environments (Harmailil et al., 2024).

PV modules offer a clean and abundant power source; however, their performance is inherently susceptible to environmental conditions, particularly operating temperature (Lau et al., 2018). In high-temperature tropical environments, PV panels frequently experience elevated temperatures, leading to a direct decrease in electrical efficiency, often quantified

as a reduction of approximately 0.3% to 0.65% for every 1°C increase above standard test conditions (Karthikeyan & Johnson, 2020; Lau et al., 2018). Beyond efficiency losses, prolonged exposure to high temperatures accelerates module degradation and reduces their operational lifespan (Almukhtar et al., 2023). Consequently, effective thermal management is crucial for maximizing the energy yield and economic viability of PV installations in these challenging climates. The escalating global energy demand has underscored the pivotal role of solar photovoltaic technology in the transition towards sustainable energy systems. Figure 3 depicts the global solar energy installed capacity from 2011 to 2021.

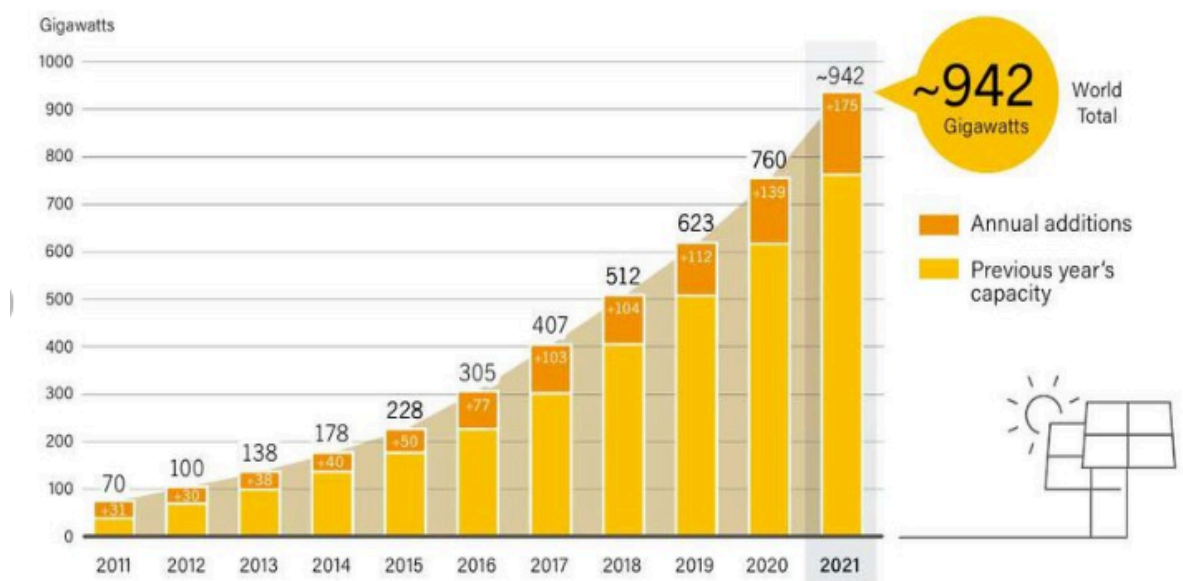

Figure 3: Global installed PV capacity from 2011 – 2021

Based on the global installed PV capacity as shown in Figure 3, in 2011, the global installed PV capacity was about 70 GW, marking the early growth phase of solar energy. The capacity increased to approximately 100 GW in 2012, driven mainly by European installations. By 2013, global PV capacity reached around 138 GW, showing steady market expansion. In 2014, installed capacity rose to about 178 GW, supported by falling module prices. The year 2015 recorded nearly 230 GW, with China becoming a major contributor. Global PV capacity expanded rapidly to about 303 GW in 2016. By 2017, installed capacity surpassed 400 GW, reflecting strong policy and investment support. In 2018, global PV capacity reached approximately 505 GW. Capacity increased further to around 627 GW in 2019 and 760 GW in 2020. By 2021, global installed PV capacity exceeded 940 GW, confirming solar PV as a mainstream energy source.

PV Module Cooling Techniques

Various cooling methods based on heat transfer mechanisms can be classified into different categories, as illustrated in the cooling classification framework. Photovoltaic (PV) cooling techniques are broadly divided into passive and active approaches (Ahmad et al., 2021; Harmailil et al., 2024). Passive cooling systems do not require external electrical power to operate; instead, they rely on natural heat transfer processes such as natural convection, conduction, and radiation to dissipate excess heat from the PV module to the surrounding environment (Bijjargi et al., 2016). In this approach, heat generated within the PV cells is transferred from the module surface and released into the ambient air through buoyancy-driven airflow.

In contrast, active cooling systems depend on external electrical energy to drive mechanical components such as fans or pumps, which enhance coolant flow and heat removal from the PV module surface (Harmailil et al., 2024). Although active cooling methods generally provide higher cooling capacity and more effective temperature reduction than passive techniques, they increase system complexity, energy consumption, and operational costs, which may reduce overall system efficiency (Ahmad et al., 2021).

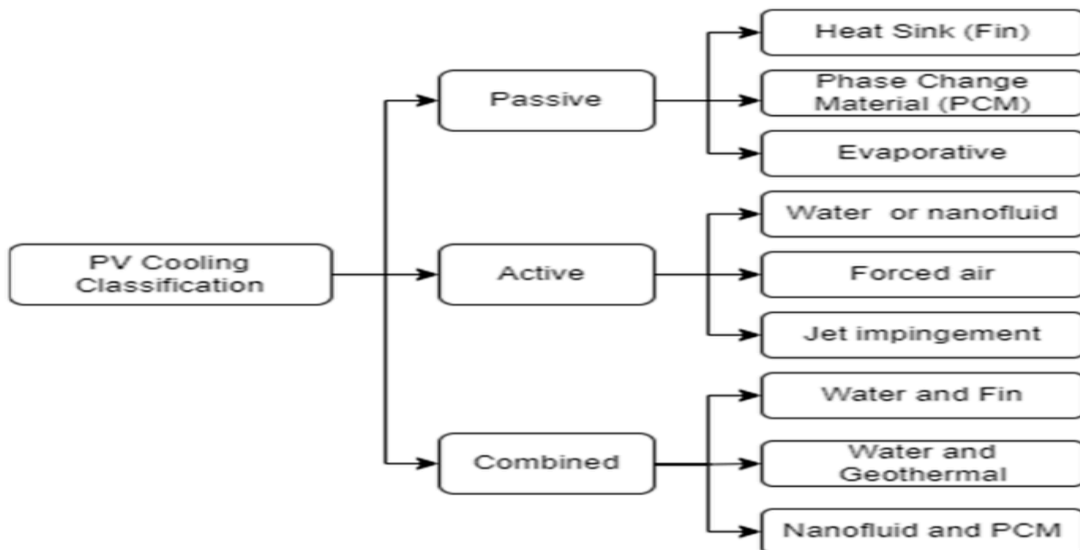

Figure 4: Classification of PV cooling methods

Active Cooling

Active cooling represents a major category of photovoltaic (PV) thermal management techniques that utilize mechanical assistance, such as fans, pumps, or suction devices, to enhance coolant flow and improve heat transfer from the PV module surface

(Bijjargi et al., 2016; Harmailil et al., 2024). In water-based active cooling systems, pumps are employed to generate forced fluid circulation, allowing control of coolant velocity and thereby regulating PV panel temperature more effectively than natural convection alone (Ahmad et al., 2021). Although active cooling methods can achieve significant temperature reductions, their reliance on external electrical energy increases system complexity and operational costs, which may offset overall energy gains in PV applications (Harmailil et al., 2024). Some of the active cooling techniques are:

- i. Water and Nano fluid Cooling (Liquid Cooling)

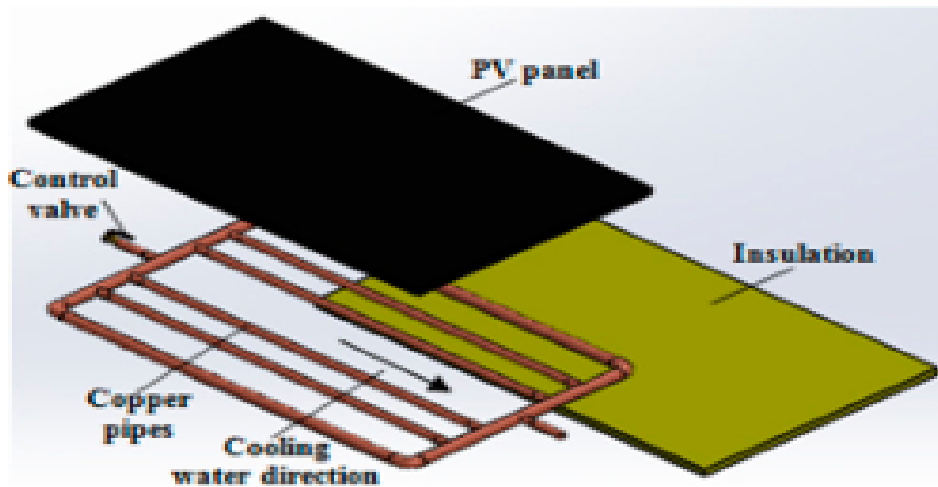

Figure 5: PV Liquid cooling Layout

- ii. Air Cooling



Figure 6: PV Air cooling Layout

Disadvantages of Active Cooling

1. High Energy Consumption (Parasitic Power Loss)

Active cooling systems (fans, pumps, thermoelectric devices) require external power to operate. This reduces the net energy gain from the PV system. In some cases, the energy used for cooling can offset part of the efficiency improvement. (Faisal et al., 2021)

2. Increased System Cost

Active cooling involves additional components such as pumps, pipes, sensors, and controllers. It leads to higher initial investment and installation costs and also increases operational and maintenance expenses. (Bijjargi et al., 2016)

3. Maintenance Requirements

Active systems require regular servicing: Pumps and fans can fail over time. Water-based systems may suffer from leakage, clogging, or scaling. This reduces reliability, especially in remote or rural installations.

4. Water Usage and Resource Dependency

Some active cooling methods use water (e.g., spraying or flowing systems): Not suitable in water-scarce regions. It requires a continuous water supply and management. (Ahmed et al., 2025)

5. System Complexity

Active cooling increases system complexity due to sensors, controllers and IoT integration. Fluid flow systems or electrical components also require an energy supply, thereby increasing the energy requirement of the cooling system.

6. Risk of Component Failure

More moving and electronic parts increase the risk of mechanical failure (fans, pumps), electrical faults and system downtime.

7. Reduced Sustainability

Active cooling systems require external energy input, which will eventually lead to an increase in carbon footprint (especially if powered by non-renewable sources) (Faisal et al., 2021).

8. Potential Overcooling or Inefficiency

If the cooling system is not properly controlled, cooling may be excessive or poorly timed, and it may lead to wasted energy and resources (Ahmed et al., 2023)

PASSIVE COOLING

Passive cooling is defined as a broad class of photovoltaic (PV) cooling techniques that rely on natural fluid flow without the use of external electrical power (Ahmad et al., 2021; Harmailil et al., 2024). Unlike active cooling systems, passive cooling does not require pumps or fans; instead, it utilizes the natural circulation of air or water to remove excess heat from PV panels. However, the cooling capacity of passive systems is inherently limited, as the dissipation of absorbed heat depends strongly on ambient environmental conditions (Bijjargi et al., 2016).

Natural convection is the primary heat transfer mechanism in passive air-cooling systems. As the PV panel heats up, the surrounding air temperature increases, causing a reduction in air density. The warmer, lighter air rises and is replaced by cooler ambient air, forming buoyancy-driven convection currents that facilitate heat removal from the module surface (Harmailil et al., 2024). One effective approach to enhancing natural convection is increasing the heat transfer surface area through the incorporation of fins or extended surfaces, which has been shown to significantly improve passive cooling performance (Ahmad et al., 2021).

Some passive techniques are:

- i. Heat Sink

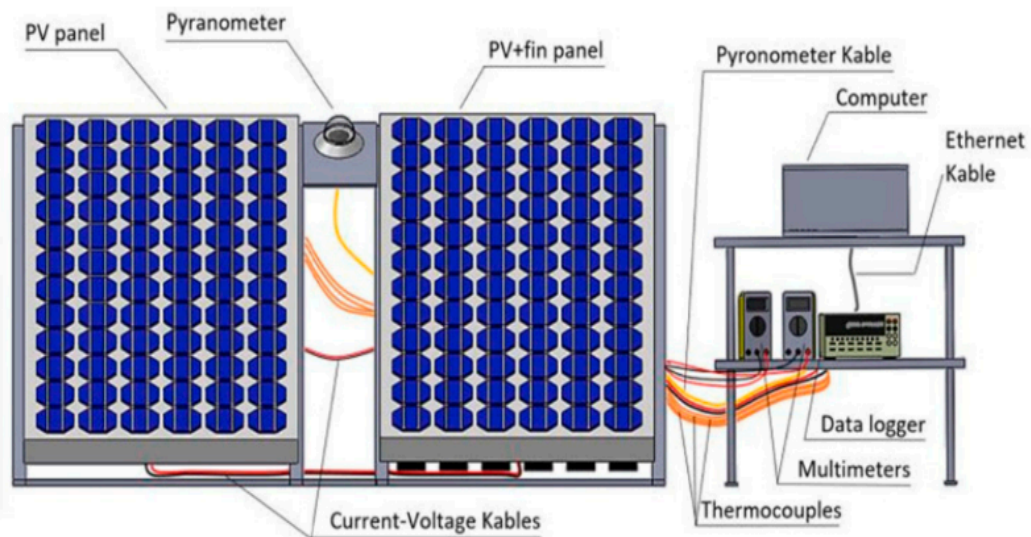

Figure 7: PV Heat Sink Cooling Layout

- ii. Phase Change Materials (PCMs)

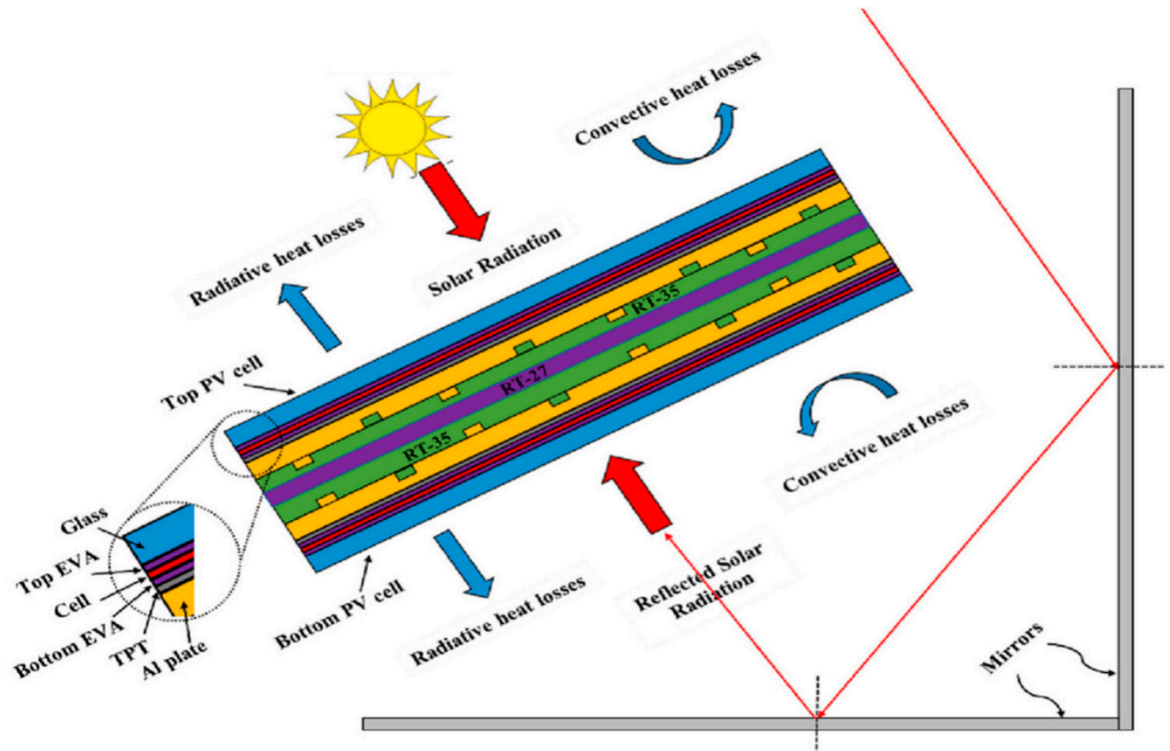

Figure 8: PV Cooling System with PCM (Phase Change Material)

3.3 Governing Equations for Passive Cooling of PV Modules

1. Energy Balance of PV Module

The energy balance of a PV Module at steady state is presented as Equation 1:

$$\alpha GA - \eta(T)GA = Q_{Conv} + Q_{Rad} + Q_{Cond} \quad 1$$

Where:

αGA = absorbed solar energy

$\eta(T)GA$ = electrical power output

Remaining energy is dissipated through convection, radiation, and conduction

Efficiency decreases with temperature and is presented as Equation 2

$$\eta(T) = \eta_{ref} [1 - \beta(T - T_{ref})] \quad 2$$

1. Conduction (Heat Transfer through Layers)

The conduction heat transfer through the layers of the PV Module can be calculated by using Equation 3.

$$Q_{cond} = KA \frac{(T_1 - T_2)}{2a} \quad 3$$

For a multilayer PV structure:

$$R_{th} = \sum \frac{L_i}{k_i A} w \quad 4$$

2. Natural Convection (Passive Air Cooling)

The convection heat transfer through the layers of the PV Module and the Heat transfer coefficient can be determined using Equations 5 and 6, respectively.

$$Q_{conv} = h A (T_s - T_{\infty}) \quad 5$$

$$Nu = CRa^n \quad 6$$

Rayleigh number: The Rayleigh number determines the strength of natural convection and the effectiveness of passive cooling (Salameh et al., 2023).

$$Ra = \frac{(g\beta(T_s - T_{\infty})L^3)}{\nu\alpha} \quad 7$$

3. Thermal Radiation (Surface-to-Ambient or Sky)

The radiation heat transfer through the surface of the PV Module and the atmosphere can be determined using Equation 8 or 9.

$$Q_{rad} = \varepsilon\sigma A (T_s^4 + T_{sur}^4) \quad 8$$

$$Q_{rad} = h_{rad} A (T_s - T_{sur}) \quad 9$$

4. Combined Heat Loss Model (Simplified Form)

Equation 10 can be used to determine the combined heat loss (heat loss through conduction, convection and or radiation). This equation is commonly used in passive PV cooling studies.

$$\alpha GA - \eta(T) GA = A(h + h_{rad})(T_m - T_{\infty}) \quad 10$$

Role of CFD in PV Thermal Analysis

Computational Fluid Dynamics has emerged as a powerful and cost-effective tool for analyzing complex thermal and fluid dynamic interactions within PV systems (Ahmed et al., 2025; Al-Azawiey et al., 2023). CFD simulations enable researchers to predict intricate details such as temperature distributions, airflow patterns, and heat transfer coefficients around PV modules under various operating conditions and design configurations without the need for extensive experimental setups (Al-Azawiey et al., 2023). This numerical approach provides invaluable insights into optimizing passive cooling designs, including fin structures and air channels, to enhance convective heat removal (Elkhoundafi & Elgouri, 2025; Harmailil et al., 2024). Despite significant advancements in PV cooling research, a focused investigation into passive air cooling strategies specifically tailored for the unique climatic conditions of high-temperature tropical environments remains essential. CFD allows for the prediction of fluid flow, heat, and mass transfer within complex geometries, enabling detailed analysis of thermal

behavior without extensive physical experimentation (Ahmed et al., 2025; Al-Azawiey et al., 2023). Commercial software like ANSYS Fluent is frequently used for such simulations, providing insights into temperature distributions and cooling performance for various designs (Al-Azawiey et al., 2023). While CFD models offer high spatial and temporal resolution, they can be computationally expensive; however, they are invaluable for research and prototype validation (Apribowo et al., 2025). The accuracy of CFD models is often validated against experimental data, ensuring reliable prediction of thermal and fluid dynamic behaviors (Al-Azawiey et al., 2023).

Review of past related literature

Under tropical ambient conditions, the PV module experiences substantial heat accumulation when no effective cooling mechanism is applied. The highest temperatures are concentrated at the central region of the PV cells (Pomares-Hernández et al., 2021; Harmailil et al., 2024). The efficiency of PV and the rate of power output decline significantly at peak sunlight due to heat accumulation (Idoko, Anaya-Lara & McDonald, 2018). Faisal et al. (2021) further reported that excessive heat on PV panels causes approximately 5% efficiency loss per 10 °C rise in temperature. Therefore, these findings confirmed that a rise in temperature of PV panels leads to a reduction in efficiency and power output of the panels; as such, there is a need for effective cooling of the panels. Ahmad et al. (2021 and Harmailil et al. 2024) reported that a reduction in photovoltaic (PV) module operating temperature directly improves electrical efficiency and power output, in accordance with well-established temperature-dependent PV performance correlations. Lower cell temperatures lead to an increase in open-circuit voltage and a reduction in charge carrier recombination losses, thereby enhancing overall electrical performance. PV cooling techniques are broadly divided into passive and active cooling approaches (Ahmad et al., 2021; Harmailil et al., 2024).

Reports from Ahmad et al., (2021) and Zhang et al., (2024) revealed that the introduction of passive air cooling to the PV system, the temperature distribution becomes more uniform across the module surface. These airflow structures reduce the thermal boundary layer thickness and enhance convective heat transfer from the PV module (Pomares-Hernández et al., 2021; Harmailil et al., 2024). The authors further reported that Velocity contour results indicate that natural convection generates low-magnitude but well-structured airflow patterns around the photovoltaic (PV) module. Higher air velocities are observed near the rear surface and along inclined edges, where buoyancy-driven

thermal plumes develop due to temperature gradients between the heated module surface and the surrounding air. Snousi & Charabib (2025) reported States that Floating PV systems exhibited 8–12% higher efficiency than ground-mounted systems due to natural water-based cooling. Floating PV is recommended for regions with available water bodies, combined with intelligent control strategies to enhance long-term performance. In another research, Majumder et al. (2023) found that floating PV systems benefit from natural water cooling, achieving up to 30% efficiency improvement while reducing water evaporation. Floating PV systems are recommended for hot regions with water scarcity due to their dual energy–water conservation benefit.

Amber et al. (2020) and Bayrak et al. (2020) studied the use of fins (rectangular and circular fin) heat sinks for passive PV cooling and reported that rectangular fins dissipated 155% more heat than uncooled modules and improved efficiency by 14.5%. Similarly Idoko et al., (2018) also reported that using multi-concept passive cooling system (conductive heat sink, air cooling, and surface water cooling), PV surface temperature was reduced to about 20 °C, eventually resulting in a power increase of 20.96 W and an efficiency gain of over 3%. Furthermore, Abdullah et al. (2020) reported that fin–base passive cooling combinations reduced PV temperature by up to 22 °C, leading to notable efficiency improvements. Use of Optimized heat-sink material combinations should be adopted to maximize passive cooling without additional energy consumption. Abdulmouti (2023) conducted an investigation on air-channel and chimney-based PV passive cooling methods and revealed that the method can effectively reduce PV operating temperature and improve electrical efficiency without external energy consumption. Passive air-chimney cooling systems are suitable for desert and arid climates due to simplicity, reliability, and zero parasitic power demand. Liu et al. (2023). Al-Azawiey et al. (2023) opined that optimized fin orientations (45° and 90°) reduced PV backside temperature to 4.2–9.5 °C above ambient, while 135° fins worsened cooling. Karthikeyan & Johnson (2020) also related that aluminum fin heat sinks showed that optimized fin geometry (40 mm height, 1.5 mm thickness, 30 mm spacing) reduced panel temperature by about 4°C under natural convection. Elkhoundafi & Elgouri (2025) reported that experimental testing of aluminum heat sinks showed an average 8.13 °C temperature reduction and a rise in open-circuit voltage by 0.51 V. Hudisteanu et al. (2021), found that perforated heat sink fins significantly enhance convective heat transfer, increasing PV power output by up to 6.49% under low-wind conditions. And recommended the use of Perforated fin heat sinks should

be adopted in naturally ventilated PV systems, particularly where wind speeds are low. Mahdavi et al. (2022) conducted a comprehensive review and reported that PV efficiency decreases by 0.4–0.65% per °C rise. Among passive methods, natural air ventilation and fin-assisted convection were found to be most economically viable. Hamdan et al. (2023) also conducted an experimental evaluation of L-shaped aluminum fins as a means of passive PV module cooling, and the findings demonstrated a 9.2 °C temperature drop and an 8.9% efficiency increase at optimal fin spacing. Fin geometry and spacing must be optimized, with 2 cm spacing identified as optimal for natural convection cooling. Cabrera-Escobar et al. (2024) reported that FEM analysis showed that perforated copper fins provided the highest temperature reduction and efficiency gains among tested heat-sink designs. Perforated metallic fins should be prioritized in passive cooling designs to enhance convection and reduce thermal resistance.

References

1. Ahmad, E. Z., Sopian, K., Jarimi, H., Fazlizan, A., Elbreki, A., Abd Hamid, A. S., Rostami, S., & Ibrahim, A. (2021). Recent advances in passive cooling methods for photovoltaic performance enhancement. *International Journal of Electrical and Computer Engineering*, 11(1), 146–154.
2. Ahmed, Y. E., Pasupuleti, J., Alhousni, F. K., & others. (2025). Designing integrated intelligent control systems for photovoltaic cooling and dust panels based on IoT: Kirkuk study, Iraq. *Renewable Energy Systems Journal*.
3. Al-Azawiey, S. S., Mohamed, M. M., & Arifin, A. B. (2023). Effectiveness of PV/T passive natural air cooling by backside attached fins. *Energy Reports*.
4. Almkhtar, H., Lie, T. T., Al-Shohani, W. A. M., Anderson, T., & Al-Tameemi, Z. (2023). Comprehensive review of dust properties and their influence on photovoltaic systems: Electrical, optical, thermal models and experimentation techniques. *Energies*, 16(8), 3401.
5. Apribowo, C. H. B., Tjahjana, D. D. P., Trisnoaji, Y., & others. (2025). Mathematical modeling and optimization of photovoltaic–phase change material cooling systems for enhanced thermal management in public electric vehicle charging stations. *Journal Européen des Systèmes Automatisés*, 58(9), 1861–1878.
6. Arifin, Z., Prasetyo, S. D., Rachmanto, R. A., & others. (2023). Optimizing photovoltaic thermal collector temperature with varying number of collectors: A CFD simulation study. *Applied Thermal Engineering*.
7. Atia, D. M., Hassan, A. A., El-Madany, H. T., & others. (2023). Degradation and energy performance evaluation of mono-crystalline photovoltaic modules in Egypt. *Energy Reports*.
8. Badi, N., & Laatar, A. H. (2024). Improved cooling of photovoltaic panels by natural convection flow in a channel with adiabatic extensions. *International Journal of Thermal Sciences*.

9. Barbu, I.-M. (2021). Étude et optimisation des capteurs solaires photovoltaïques thermiques hybrides et de leur intégration dans des systèmes énergétiques de petite taille destinés aux prosommateurs (Doctoral dissertation).
10. Bayrak, F., Oztop, H. F., & Selimefendigil, F. (2020). Experimental study for the application of different cooling techniques in photovoltaic (PV) panels. *Energy Conversion and Management*, 212, 112789.
11. Bijjargi, Y. S., Kale, S. S., & Shaikh, K. A. (2016). Cooling techniques for photovoltaic module for improving its conversion efficiency: A review. *International Journal of Mechanical Engineering and Technology*, 7(4), 22–28.
12. Cabrera-Escobar, R., Cabrera-Escobar, J., Vera, D., Jurado, F., Orozco-Cantos, L., Córdova-Suárez, M., & García-Mora, F. (2024). Comparative analysis of material efficiency and the impact of perforations on heat sinks for monocrystalline photovoltaic panel cooling. *Energies*, 17(21), 5511.
13. Elkhoundafi, O., & Elgouri, R. (2025). Development and testing of a dedicated cooling system for photovoltaic panels. *International Journal of Electrical and Computer Engineering*, 15(5), 4387–4394.
14. Enasel, E., Lupu, A.-G., & Dumitraşcu, G. (2023). Design and development of cooling systems for PV cells performance improvement. *Energies*, 16(12), 4567.
15. Fahad, A. S., Osman, K., Abidin, U., Ahmad, M. S., Ismaeil, E. M. H., & Farooq, M. U. (2025). Review of cooling techniques for improving solar photovoltaic panel efficiency. *Journal of Advanced Research in Fluid Mechanics and Thermal Sciences*, 125(1), 193–219.
16. Faisal, F., Rashel, M. R., Tlemçani, M., & Ahmed, M. T. (2023). A comparative review on cooling techniques to develop hybrid PV/T panel. *IEEE Conference Proceedings*.
17. Fuentes-Hernández, D., Vargas Ramírez, M., Legorreta García, F., & others. (2024). Computational simulation in solar energy: Effect of passive cooling in the generation of photovoltaic cells in Pachuca de Soto, Mexico. *Sustainable Energy Technologies and Assessments*.
18. Glick, A., Ali, N., Bossuyt, J., & others. (2020). Utility-scale solar PV performance enhancements through system-level modifications. *Progress in Photovoltaics: Research and Applications*, 28(6), 497–512.
19. Glick, A., Smith, S. E., Ali, N., & others. (2020). Influence of flow direction and turbulence intensity on heat transfer of utility-scale photovoltaic solar farms. *Solar Energy*, 206, 627–639.
20. Hamad, A. J., Hussein, F. M., & Tarish, A. L. (2023). Evaluating the effects of air cooling on photovoltaic module performance in hot climates: A comprehensive numerical and experimental investigation. *Energy Conversion and Management*.
21. Hamdan, M., Abdelhafez, E., Al-Aboushi, A., Othman, A., Al-Saleh, S., & Ajib, S. (2023). Enhancing PV modules performance using L-shaped aluminum fins. *International Review of Mechanical Engineering*, 17(2), 48–56.
22. Harmailil, I. O., Sultan, S. M., Tso, C. P., Fudholi, A., Mohammad, M., & Ibrahim, A. (2024). The state of the art of photovoltaic module cooling techniques and performance assessment methods. *Symmetry*, 16(4), 412.
23. Hussien, A., Eltayesh, A., & El-Batsh, H. M. (2022). Experimental and numerical investigation for PV cooling by forced convection. *Energy Reports*.

24. Karthikeyan, M., & Johnson, J. (2020). Analysis and performance improvements of photovoltaic system using fins for heat reduction by CFD. *International Journal of Engineering Research and Technology*.
25. Kumar, R. S., Priyadharshini, N., & Natarajan, E. (2015). Experimental and computational fluid dynamics study of glazed three-dimensional PV/T solar panel with air cooling. *Energy Conversion and Management*, 103, 907–917.
26. Lau, S.-K., Zhao, Y., & Shabunko, V. (2018). Optimization and evaluation of naturally ventilated BIPV façade design. *Energy and Buildings*, 164, 281–295.
27. Majumder, A., Kumar, A., Innamorati, R., Mastino, C. C., Cappellini, G., Baccoli, R., & Gatto, G. (2023). Cooling methods for standard and floating PV panels. *Energies*, 16(24), 7939.
28. Pomares-Hernández, C., Zuluaga-García, E. A., Escorcía-Salas, G. E., Robles-Algarín, C., & Sierra Ortega, J. (2021). Computational modeling of passive and active cooling methods to improve PV panels' efficiency. *Applied Sciences*, 11(23), 11370.
29. Wang, Y., Xiao, C., & Bedon, C. (2024). Performance of photovoltaic panels with different inclinations under uniform thermal loading. *Solar Energy*, 262, 112–123.
30. Zhang, G., Misaran, M. S., Zhang, Z., Radzali, M. A., & Ismail, M. A. (2024). Solar photovoltaic surface cooling using hybrid solar chimney-collector with wavy fins. *Journal of Advanced Research in Numerical Heat Transfer*, 22(1), 46–58.



© 2026 by the authors. Submitted for possible open access publication under the terms and conditions of the Creative Commons Attribution (CC BY) license (<https://creativecommons.org/licenses/by-nc-sa/4.0/>).