Review

Sustainable Biodiesel Production Pathways in Nigeria: A Review of Feedstock Options, Production Methods and Engine Performance

Muyiwa Abiodun OKUSANYA^{1*}, Emmanuel Atto AJAV²

¹Agricultural and Bioenvironmental Engineering Department, The Federal Polytechnic Ilaro, P.M.B. 50, Ilaro, Ogun State, Nigeria. <https://orchid.org/0000-0002-1922-5213>

²Professor Agricultural and Environmental Engineering Department, University of Ibadan, Ibadan, Oyo State, Nigeria.

Correspondence should be addressed to: muyiwa.okusanya@federalpolyilaro.edu.ng

Abstract: Nigeria's energy sector for transportation currently uses petroleum diesel, which has resulted in the increase of greenhouse gases, air pollution, and energy insecurity in the country. The use of the more environmentally friendly biodiesel will thus offer the country an alternative for diversification, job creation, and environmental enhancement. The paper aims to critically examine the recent developments in the available processes for the production of biodiesel, with specific reference to the Nigerian situation, as well as successful international programs implemented in Brazil, India, Indonesia, the EU, and the US. The paper will examine the available feedstock, which can be categorized into four major categories, namely waste cooking oils, non-edible oils, microalgae, and animal fats, and evaluate the availability, yield, and sustainability of each of the available feedstocks for the production of biodiesel. The available conversion processes, such as trans-esterification, hydrotreated vegetable oil (HVO), and the emerging thermochemical processes, will also be examined. The performance characteristics of the engine and the emission impact are also discussed, including combustion efficiency, the balance between the formation of NO_x and PM, and fuel compatibility in compression ignition engines. Case studies in different countries have proven that feedstock diversification, policy consistency, and technology integration are important in the scale-up of biodiesel technology. Research gaps have also been identified in Nigeria, including feedstock logistics, catalyst optimization, and environmental impact assessment. The study has also recommended the development of an adaptive national strategy that includes the integration of the circular economy concept, feedstock valorization, and regional cooperation in the development of sustainable biodiesel in Nigeria.

Keywords: Biodiesel, Feedstock, Trans-esterification, Engine Performance, Renewable Energy, Nigeria.

1.0 Introduction

The global concerns regarding climate change, depletion of fossil fuels, and deteriorating air quality have sparked interest in exploring alternative fuels to petroleum products. Biodiesel is one such alternative fuel that is considered to be one of the major alternatives to petroleum products due to its biodegradable nature, suitability for diesel engines, and low carbon footprint (Silva et al., 2023; IEA, 2024). The global biodiesel market is growing steadily for various reasons, such as mandates, diversification strategies, and security concerns. Countries such as Brazil, Indonesia, the United States, and European Union nations have implemented successful policies for biodiesel that link agricultural productivity with energy policies.

For example, in Nigeria, fossil fuels still dominate the energy sector; 60% of the total energy consumed in transportation is diesel. However, due to this high dependence on imported diesel, there is increased pressure on the Nigerian treasury as well as the environment (Adewale et al., 2021). Biodiesel fuels offer Nigeria an opportunity to diversify its energy mix, enhance its energy security, and boost its rural economy. Nigeria is endowed with large resources of *Jatropha curcas*, *Pongamia pinnata*, castor oil plant, waste cooking oil, algae, among other resources that are still going to waste (Igwebuike, 2023; Chisti, 2020).

However, limitations to the enforcement of regulations, investment in research, and the logistics of the feedstock are still a challenge (FAO, 2023). Global success stories show how imperative it is to invest in technological and policy flexibility (IRENA, 2023; OECD, 2022). This review seeks to provide a summary of the research articles available within the last five years (2019-2024), concerning the different facets of biodiesel feedstock, the processes involved in the manufacture of biodiesel, and finally, engine performance to provide critical research and policy directions for the energy transition in Nigeria.

2.0 TYPE OF FEEDSTOCK FOR BIODIESEL PRODUCTION

2.1 Edible Oils (First Generation Feedstocks)

Edible oils such as palm oil, soybean oil, sunflower oil, and canola oil are among the earliest biofuel feedstocks to be commercially produced due to their low FFA composition and high energy conversion rates. Countries such as Brazil and Argentina have successfully commercialised their biofuel industry using edible oils like soybean oil, thanks

to favourable government policies and blending targets (Silva et al., 2023; Reuters, 2025). Other countries, including Indonesia and Malaysia, have also successfully harnessed edible oils like palm oil to achieve their biofuel blending targets (Khan et al., 2022).

The edible oil-based biofuel industry has also been seen to have serious food-fuel trade-offs in developing countries. Using edible oils for biofuel purposes has significant implications for food security in these regions. Developing countries will have to face the brunt of food insecurity and increased dependence on imports if edible oils are used for biofuel purposes (Adewale & Mustapha, 2021). In Nigeria, for instance, edible oil production is already in short supply in the local market.

In addition, the cultivation of palms and soybeans on a large scale has the potential to cause deforestation, biodiversity loss, and carbon debt, thereby negating the sustainability advantages of biodiesel (Anyaocha et al., 2019; IRENA, 2023). Therefore, edible oil is not advised as the primary feedstock for Nigeria, although it could be considered in the early stages of biodiesel development.

2.2 Non-Edible Oils (Second Generation Feedstocks)

Non-edible oil crops are becoming the choice of the future for sustainable biodiesel production due to the avoidance of food security issues and their ability to grow in marginal lands. Prominent non-edible oil crops include *Jatropha curcas*, *Pongamia pinnata*, the castor oil plant, neem, and mahua. These crops have already been successfully employed in India, Kenya, and Ghana for biodiesel production. They are well adapted to the tropical climates of these countries (IRENA, 2023; Sahoo et al., 2022).

In Nigeria, *Jatropha curcas* is the best-studied non-edible oil crop. This crop has the advantages of a high oil yield content (30-40%) and can be cultivated in arid and semi-arid climates with minimal inputs. The major disadvantage of this crop is the variable yield due to improper agronomic practices, limited cultivation, and the absence of seed commercialisation programmes (FAO, 2023).

It has the potential to be improved through hybridisation, genetic development, and mechanical processing, which could make it more financially viable (Adejumo et al., 2024). Non-edible oil farming could also be integrated with agroforestry practices, which could help in soil conservation and rural employment generation. Other plant species, such as *Pongamia pinnata* and Castor, present additional opportunities as well, with improved oxidative stability and viscosity characteristics according to the ASTM D6751 biodiesel standard (Sahoo et al., 2022).

2.3 Waste and Residual Oils (Third-Generation Feedstocks)

Waste cooking oil (WCO) and animal fat are viable low-cost, low-carbon options that align with the principles of a circular economy. WCO-based biodiesel is gaining traction worldwide, driven by the availability of the resource, low raw material costs, and the positive environmental impacts of waste reduction (Bhardwaj et al., 2021). The EU and China have implemented waste oil collection infrastructure for restaurant and household waste, thereby reducing raw material costs (IEA, 2024; ICCT, 2024).

In Nigeria, waste cooking oil from urban centres like Lagos, Abuja, and Port Harcourt is currently uncollected or improperly disposed of, thereby polluting the environment (Adewale et al., 2021). The establishment of waste oil collection infrastructure can provide a consistent raw material supply for small- and medium-scale biodiesel plants. Other raw materials can be sourced from abattoirs, including animal tallow and lard.

The major challenge associated with the process is the high content of fatty acids in the feedstock, which needs to be pretreated with acid esterification prior to transesterification to prevent soap formation and catalyst deactivation (Kumar et al., 2023). In spite of the challenges associated with the process, the energy balance and reduction of GHG emissions of biodiesel are favourable compared to petroleum diesel fuel (Bhardwaj et al., 2021).

2.4 Microalgae and Advanced Biomass (Fourth-Generation Feedstocks)

Microalgae are considered to be the most promising long-term feedstocks due to their high oil productivity of up to 80,000 L/ha/year, fast growth rates, and ability to capture CO₂. Microalgae species such as *Chlorella vulgaris*, *Nannochloropsis* sp., and *Botryococcus braunii* have been widely investigated for biodiesel production in countries such as the US, Japan, and China (Kumar et al., 2023).

For instance, in Nigeria, there is an abundance of freshwater and coastal areas that can be used for algal culture (FAO, 2023). However, for commercialisation to be effective, there is still a need to reduce costs associated with harvesting and lipid production. New technologies such as PBRs, co-cultivation in wastewater, and biorefineries can be used to improve the commercialisation process (Chisti, 2020; Han et al., 2022).

For microalgae cultivation, there is an added advantage of co-products such as proteins and pigments that can be used to improve the process economics (IEA, 2024). In Nigeria, one of the strategies that can be employed for microalgae technology is through university-industry collaborations for long-term development.

Figure 1: Overview of biodiesel feedstocks

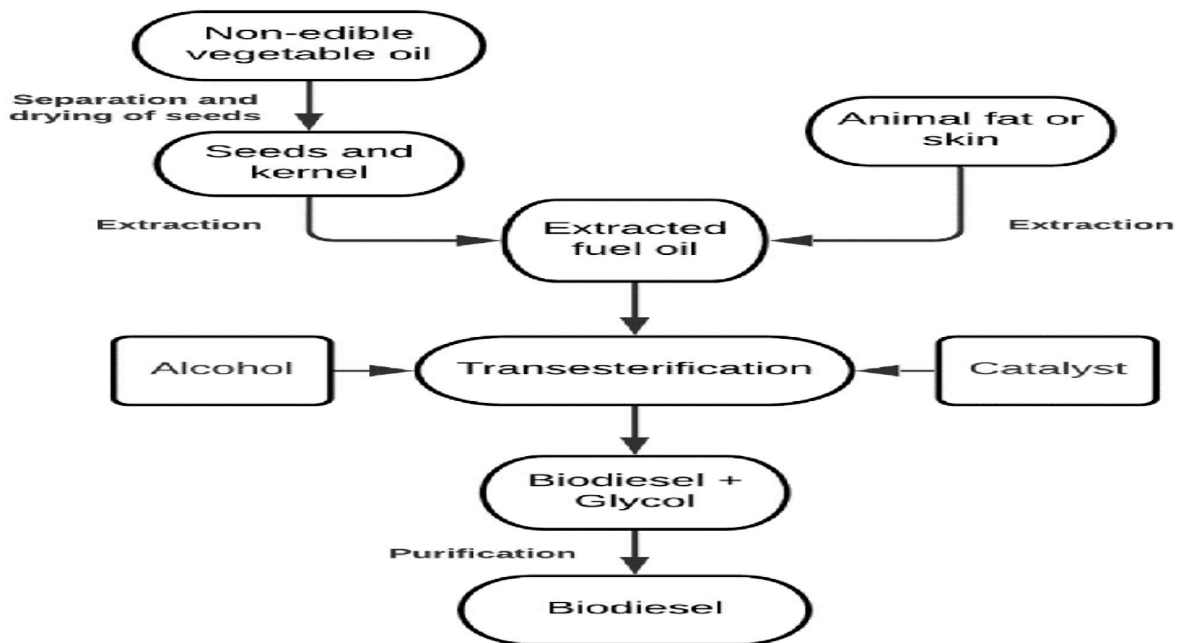

Source:

https://www.researchgate.net/figure/Flow-diagram-for-biodiesel-production-from-non-edible-vegetable-oil-2G-and-animal-fats_fig2_357886857

3.0 CONVERSION METHODS AND REACTION MECHANISMS

It has also been noted that there have been considerable changes in the process of biodiesel production in the last decade, ranging from conventional chemical reactions to modern and advanced processes involving catalysts and thermochemistry. However, the choice of process for the conversion of the feedstock to biodiesel is largely dependent on the feedstock, free fatty acids, and properties of the feedstock (Kumar et al., 2023; Han et al., 2022).

Four major technologies have been identified globally for the conversion of feedstocks into biodiesel:

- i. Transesterification Using Base, Acid, and Enzyme-Catalysed Reactions
- ii. Hydrotreated Vegetable Oil (HVO) or Renewable Diesel Production
- iii. Pyrolysis and Thermochemical Conversion of Biomass
- iv. Supercritical and Emerging Biotechnological Methods

3.1 Transesterification (Conventional Method)

Transesterification is still the most popular method for producing biodiesel worldwide. The transesterification process is based on the reaction of triglycerides present in vegetable and animal oils with short-chain alcohols such as methanol and ethanol in the

presence of a catalyst to form fatty acid methyl esters and glycerol (Adewale et al., 2021; IEA, 2024).

Reaction equation

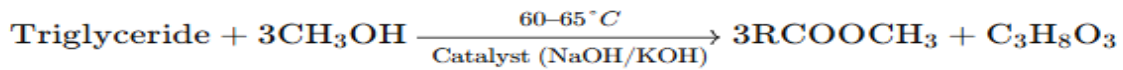

Where:

- RCOOCH_3 = Fatty Acid Methyl Esters (biodiesel)
- $\text{C}_3\text{H}_8\text{O}_3$ = Glycerol

Catalyst Types and Mechanisms

- Base catalysts (NaOH, KOH) are the most commonly used; they exhibit a high rate of reaction but are sensitive to free fatty acid (FFA) and water levels (Bhardwaj et al., 2021).
- Acid Catalysts (H_2SO_4 , HCl): Suitable for high FFA-containing feedstocks; slower rate of reaction (Kumar et al., 2023).
- Enzyme Catalysts (Lipases): Environmentally friendly, can be reused, but expensive.

Process Flow Description

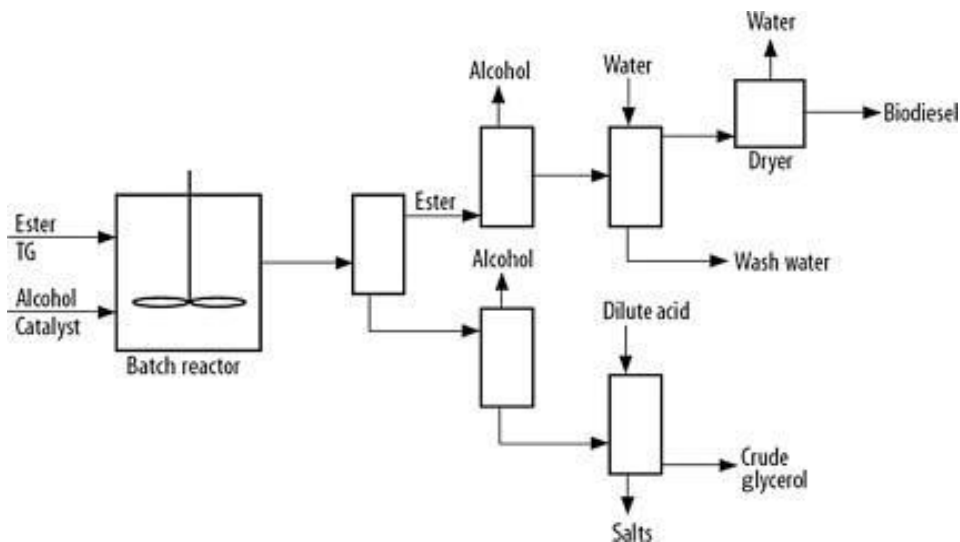

Figure 2: Base-Catalyzed Transesterification Process

Source: <https://www.sciencedirect.com/topics/engineering/refining-glycerol>

The conditions are usually set between 55-65°C, with a 6:1 ratio of methanol to oil and a 1-2% concentration of the catalyst. Proper feedstock pretreatment, especially in the case of WCO and tallow, is essential in maintaining the level of FFA below 2%, thus preventing soap formation (Silva et al., 2023). Current advances in the transesterification process have focused on the use of heterogeneous catalysts such as CaO, ZnO, MgO, and zeolite, which facilitate easier separation and reuse of the catalysts (Han et al., 2022; IRENA, 2023). This makes the process more sustainable.

3.2 Hydrotreated Vegetable Oil (HVO) - Renewable Diesel

Hydrotreated Vegetable Oil (HVO), also called renewable diesel, is rising in popularity in Europe and the United States as a substitute for petroleum diesel fuel. Unlike FAME biodiesel, HVO is hydrodeoxygenated, decarboxylated, and isomerised to produce hydrocarbons similar to petroleum diesel fuel (ICCT, 2024).

Reaction Overview

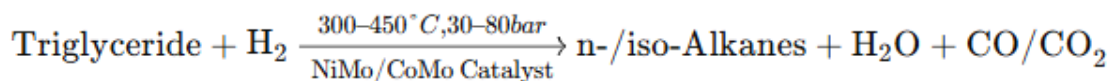

The HVO process eliminates oxygen from triglycerides, producing a sulphur-free, high-cetane, and oxidation-stable fuel (Khan et al., 2022).

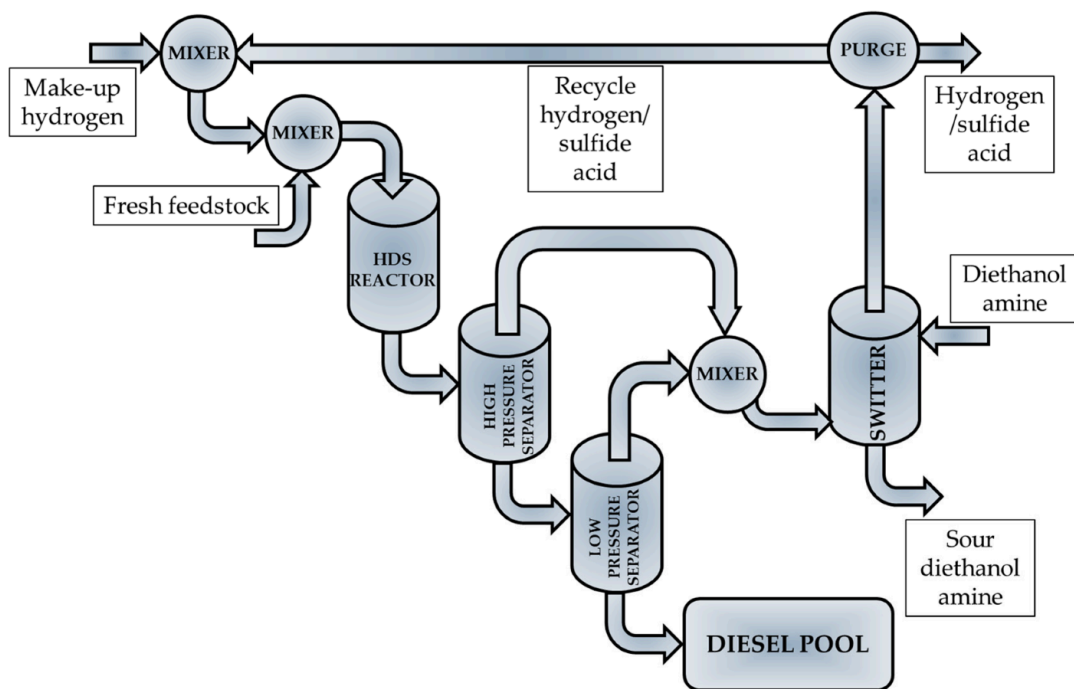

Figure 3: Simplified HVO Process Flow

Source: <https://www.mdpi.com/2227-9717/13/9/2817>

The production of HVO is capital-intensive but results in high-quality diesel fuel with fewer cold-flow problems and better storage stability than FAME. Major HVO-producing companies include Neste in Finland and ENI in Italy, while new projects in Malaysia and Indonesia utilise palm oil as feedstock material (IRENA, 2023). For Nigeria, HVO can be tailored through public-private partnerships to improve diesel blend conformity to Euro V diesel standards.

3.3 Pyrolysis and Thermochemical Conversion

Pyrolysis is a process by which biomass or lipid-rich feedstocks are transformed into bio-oil, biochar, and syngas in an oxygen-deficient atmosphere (400-600°C). The bio-oil obtained in this process can be further transformed into biodiesel by means of catalytic cracking or transesterification reactions (Anyaocha).

The pyrolysis process has advantages, including the acceptance of mixed or contaminated feedstocks, which can include agricultural residues and waste plastics for circular economy integration (FAO, 2023). However, the high oxygen content of crude bio-oil makes it unstable and requires hydrodeoxygenation prior to engine use (IEA, 2024).

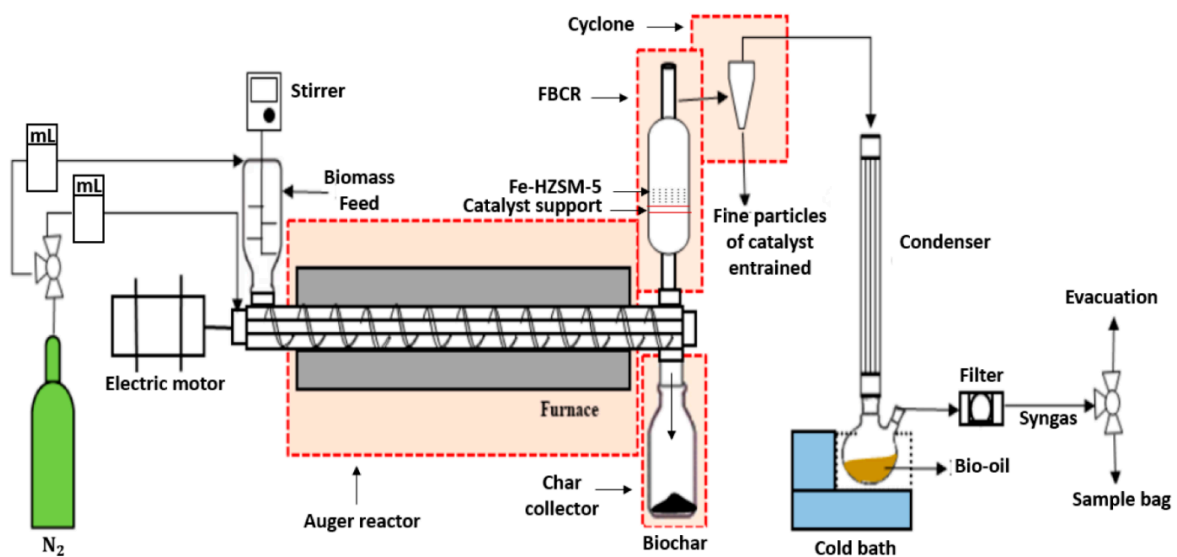

Figure 4: Schematic of the Pyrolysis Process

Source: <https://www.mdpi.com/2227-9717/12/11/2368>

Some pilot projects have been implemented in India, South Africa, and China to demonstrate examples of co-processing pyrolysis oil and petroleum feedstocks in refineries (IRENA, 2023). In Nigeria, this could be a cost-effective way to utilise agricultural waste such as cassava peel, palm kernel shell, and maize cobs for producing alternative fuels.

3.4 Supercritical and Emerging Biotechnological Methods

Supercritical alcohol transesterification uses supercritical methanol or ethanol, which has critical conditions (240°C, 80-90 bar), thus eliminating the need for any catalyst (Han et al., 2022; IEA, 2024).

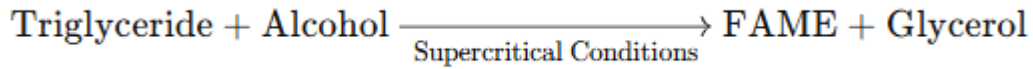

Recent research has also emphasised the development of biotechnologies such as microbial lipids (oleaginous yeasts and fungi), as well as genetically engineered algae, which secrete biodiesel precursors outside the cell (Chisti, 2020; Kumar et al., 2023). These are promising for the R&D activities being undertaken in universities in Nigeria.

Table 1:

Comparative Assessment of Conversion Methods

Method	Catalyst/Condition	Feedstock Flexibility	Product Quality	Cost Level	Suitability for Nigeria
Base Transesterification	NaOH, 60°C	Low-FFA oils	High	Low	High (short-term)
Acid Transesterification	H ₂ SO ₄ , 70°C	High-FFA oils	High	Moderate	High
HVO (Hydrotreating)	NiMo, 350°C	Flexible	Excellent	High	Medium (long-term)
Pyrolysis	None, 450°C	Very high	Moderate	Moderate	High
Supercritical	240°C, 90 bar	High	Excellent	Very high	Research phase

3.5 Adaptation for Nigeria

Nigeria's biodiesel market is in its infancy. The hybrid method, combining traditional transesterification for low-cost feedstock such as WCO and HVO for high-quality diesel blending, could be adopted. Technology collaborations with global technology providers could be established to build local expertise in catalyst regeneration, glycerol utilisation, and biorefinery integration. Biodiesel plant investments with modular capacity and the capability to handle multiple feedstocks will contribute to more jobs in

rural areas and support Nigeria's renewable energy diversification agenda through the National Energy Transition Plan (NETP), 2023.

4.0 Engine Performance, Combustion, and Emission Characteristics of Biodiesel

The actual viability of biodiesel is not only based on production but also on engine compatibility, efficiency, and emission characteristics. Various studies (2019-2025) have established that biodiesel can replace or be mixed with petroleum diesel fuel and run in compression ignition engines with minimal engine modifications (Han et al., 2022; Bhardwaj et al., 2021; IEA, 2024). This section is a synthesis of recent global studies and how they can be used to inform Nigeria's new biodiesel market.

4.1 Engine Performance Parameters

The physical and chemical properties of biodiesel, such as density, oxygen content, and viscosity, also affect engine performance, including the rate of combustion and power produced. The parameters used to assess engine performance are Brake Power (BP), Brake Thermal Efficiency (BTE), Brake Specific Fuel Consumption (BSFC), and Exhaust Gas Temperature (EGT), as mentioned by Kumar et al. (2023) and Singh et al. (2022).

4.1.1 Brake Thermal Efficiency (BTE)

The BTE of biodiesel is normally reduced by 2-5% compared to diesel due to the calorific value of biodiesel being significantly lower than that of diesel. The calorific value of biodiesel is approximately 37 MJ/kg, whereas that of diesel is approximately 43 MJ/kg. However, due to the presence of more oxygen in biodiesel, it helps in achieving complete combustion to some extent (Bhardwaj et al., 2021).

4.1.2 Brake-Specific Fuel Consumption (BSFC)

In addition, BSFC normally increases with increasing levels of biodiesel due to density and HCV effects. Biodiesels derived from palm, Jatropha, and WCO fuels have been found to have increases in BSFC ranging from 5 to 10% compared to diesel fuels. Optimisations in injection timing and compression ratio can help to mitigate this effect.

4.1.3 Engine Power and Torque

The power output of the engine is likely to reduce slightly (1-3%) when using biodiesel fuels compared to petroleum fuels. However, better fuel atomisation and lubrication may result in smoother engine operation and less wear and tear (Kumar et al., 2023; IRENA, 2023).

4.2 Combustion Characteristics

The combustion characteristics of the fuel depend on the ignition delay, peak pressure, and heat release rate. The increased cetane rating of biodiesel, ranging from 45 to 65, as opposed to 40 to 55 for diesel, improves the combustion of biodiesel by reducing the ignition delay (Han et al., 2022; Bhardwaj et al., 2022).

4.2.1 Ignition Delay and Combustion Duration

Experimental results indicate that the blends of biodiesel have a faster rate of ignition due to better auto-ignition characteristics, but the combustion duration is longer than that of diesel due to slower vapourisation rates (Chisti, 2020; Singh et al., 2022).

4.2.2 Peak Cylinder Pressure

The peak pressure tends to rise slightly in the case of biodiesel blends due to the oxygen-enriched combustion process. This increases the efficiency of the process but also raises the mechanical stress at higher ratios of blends (IEA, 2024).

4.2.3 Heat Release Rate (HRR)

The premixed combustion phase is shorter, while the diffusion combustion phase is the main phase due to the molecular composition of biodiesel. This results in a better burn with lower amounts of particulates (IRENA, 2023).

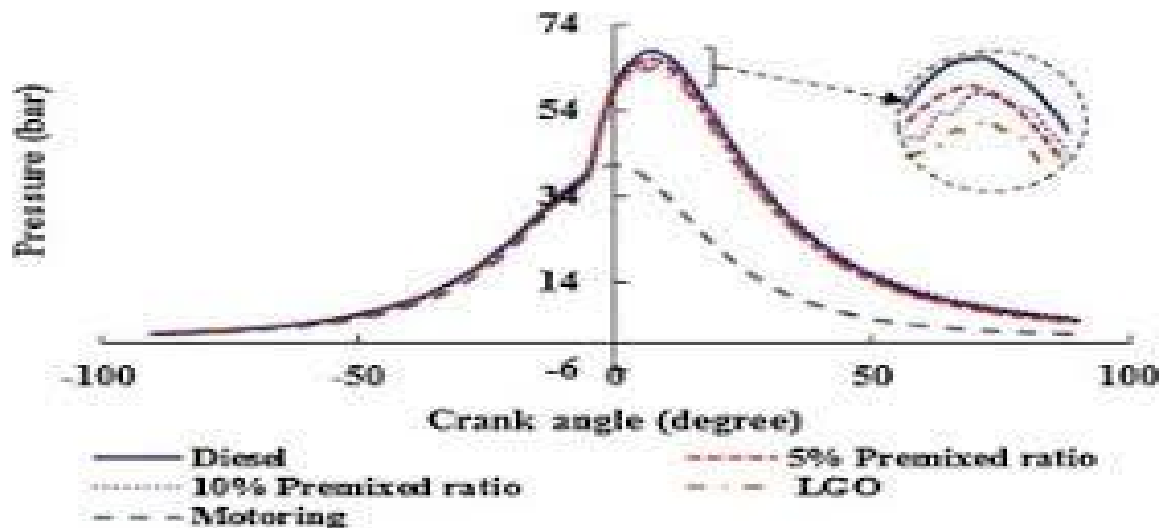

Figure 5: Comparative Combustion Phases for Diesel versus Biodiesel

Source:

https://www.researchgate.net/figure/Pressure-versus-crank-angle-diagram_fig3_277726631

4.3 Emission Characteristics

Biodiesel tends to decrease carbon-based emissions but has a neutral or even increasing effect on nitrogen oxides (NO_x).

4.3.1 Carbon Monoxide (CO)

CO emissions are reduced substantially (20-50%) for biodiesel fuels due to the presence of more oxygen, which allows for complete oxidation (Bhardwaj et al., 2021; Kumar et al., 2023).

4.3.2 Unburned Hydrocarbons (HC)

Emissions of HC decrease by 30-60% compared to diesel fuels because they facilitate complete combustion (Silva et al., 2023; Han et al., 2022).

4.3.3 Particulate Matter (PM)

The formation of particulate matter, including soot, is reduced by 40-70% because biodiesel fuels do not contain aromatics or sulphur (IEA, 2024).

4.3.4 Nitrogen Oxides (NO_x)

Emissions of NO_x tend to increase slightly by 2 to 10% due to the rise in combustion temperature and availability of oxygen (Han et al., 2022). EGR, water injection, and injection timing retardation can be used to reduce NO_x emissions (Singh et al., 2022).

4.4 Reaction Mechanisms in Combustion

The fundamental reactions in the combustion of biodiesel are similar to those in diesel fuel.

4.4.1 Simplified Reaction Pathway

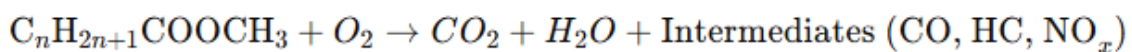

The oxygenated molecules enable the oxidation of CO and HC, and the high temperature encourages the formation of NO_x.

4.4.2 Radical Formation Sequence

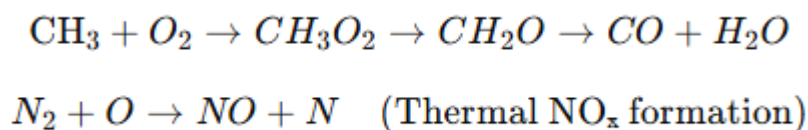

The chemical reactions show that the inherent oxygen in biodiesel ensures complete combustion but also increases NO_x formation, which is a key area of research for controlling NO_x emissions (Han et al., 2022; IRENA, 2023).

4.5 Global Case Studies and Adaptation for Nigeria

Studies in India, Brazil, and the European Union have proven that public transportation can operate on blends of B20 (20% biodiesel and 80% diesel) without any engine modifications (Silva et al., 2023; ICCT, 2024). Soot and CO₂ emissions can be reduced by 25%. The engine operates stably (IRENA, 2023).

In Nigeria, biodiesel blends can be used to reduce the import bill for diesel oil and also to clean the environment in cities. Pilot tests of biodiesel blends in city buses and farm equipment can demonstrate that the environment is being improved. By engaging with car manufacturers such as Peugeot Nigeria and Innoson Motors, it can be shown that the engine operates on biodiesel blends and that the engine is standardised for tropical conditions.

5.0 Economic, Policy, and Environmental Perspectives

The deployment of sustainable biodiesel also depends on its economics and governance, as well as its technical feasibility. This section will synthesise the information on the cost factors, market, and policies relevant to biodiesel, and then contextualise this information within the framework of Nigeria.

5.1 Life-Cycle Assessment (LCA) Evidence and Environmental Trade-Offs

As found in all LCAs, the climate change and environmental advantages of biodiesel hinge on: (i) feedstock type, (ii) land use change impacts, (iii) type of processing energy used (fossil fuels vs. renewables), and (iv) co-product allocations (ICCT, 2021; IRENA, 2022). WCO- and animal fat-based fuels generally achieve the highest GHG reductions per MJ because these feedstocks are considered residues with minimal upstream emissions (Bhardwaj et al., 2021; Avila et al., 2024). In contrast, biodiesel fuels made from edible oils exhibit increased GHG emissions when ILUC and deforestation effects are included in the calculation (EPE Brazil, 2024; Hanafy, 2025).

Hydrotreated vegetable oil (HVO) fuels may offer significant life cycle (LC) benefits, especially with green hydrogen (electrolytic H₂ derived from renewable energy sources) for the hydrotreating step, although the difference is much lower with fossil-derived hydrogen (NREL/AFDC, 2024; Gomes, 2025). Microalgae-based routes have the theoretical potential for significant CO₂ capture-related carbon intensity benefits, although the latest life cycle assessments (LCAs) show that energy-intensive harvesting,

drying, and extraction steps are the main contributors, with the inclusion of renewable energy and co-products being important (Pandey, 2024; Sharma, 2025).

Implications for Nigeria: Prioritise WCO, abattoir fats, and POME as feedstocks for early deployment to achieve maximum GHG reduction potential in the short term; mandate LCA or low-CI as a prerequisite for incentive support to avoid perverse effects of increased edible oil expansion (ICCT, 2021; Ávila et al., 2024).

5.2 Cost Structure and Key Economic Drivers

In all studies of the techno-economic aspects of biodiesel production, the largest proportion of the cost of biodiesel production is comprised of the cost of feedstocks (50 to 80%), followed by capital costs and the cost of utilities (heat and hydrogen), and finally logistics (Chimezie, 2022; NREL, 2024). Small FAME facilities have lower capital costs but higher operating costs. Large HVO facilities have much higher capital costs but also benefit from economies of scale and produce a product that can command a premium in the market. In Europe and North America, the market conditions have driven up the price of waste oil, making it more difficult for small producers to achieve a margin (Barron's, 2024; ICCT, 2024).

Nigeria specifics: the costs of aggregating feedstock supplies (collection, transportation, quality testing) are particularly high due to substandard waste collection infrastructure and long transportation distances. Local studies suggest that logistics constraints, as well as working capital constraints, bind small producers in Nigeria (Ogunkunle & Ahmed, 2019; Okoro, 2024). Incentives that mitigate feedstock supply risk (blending credits, feedstock subsidies, public offtake contracts) can increase bankability substantially (RenovaBio-like models, EPE Brazil, 2024; ICCT, 2021).

5.3 Market and Policy Instruments that Scale Production

As illustrated by global best practices, a range of successful instruments to support market development for biodiesel is available, including mandates, low-CI crediting mechanisms (such as RenovaBio in Brazil), fiscal incentives (tax incentives and loans), procurement, and support for infrastructure development for feedstock collection (ICCT, 2021; IRENA, 2022; EPE Brazil, 2024). Mandating blends (B5 to B30) can rapidly develop market demand, but this needs to be combined with sustainability and feedstock planning to avoid market shocks, as experienced in Indonesia for B30 (Wirawan, 2024). Similarly, crediting mechanisms for monetising actual CI savings (such as CBIOs in Brazil) can attract much-needed investment to low-CI producing sectors (EPE Brazil, 2024).

5.4 Recommendations for Nigeria

Nigeria should adopt a phased mandate, starting with B5-B10 in urban fleets, and at the same time launch certified WCO collection programmes and conditional fiscal support for small and medium biodiesel operators; implement a low-CI crediting mechanism rewarding verified emission reductions (ICCT, 2021; EPE Brazil, 2024).

5.5 Regulatory and Institutional Barriers

Nigeria's biofuel policy architecture is characterised by fragmentation, non-enforcement of existing rules, and obsolete standards (Ogunkunle & Ahmed, 2019; Dinneya-Onuoha, 2025). National fuel standards (ASTM/EN equivalence), test laboratories for fuels, and an integrated institutional framework among various ministries, such as energy, agriculture, and environment, must exist as prerequisites. Other cross-cutting issues include clear land tenure for biofuel crops, traceability of biofuel feedstock to avoid the use of edible oil, and protection of smallholder farmers (Paminto et al., 2022; Djatmika et al., 2023).

6.0 RESEARCH GAPS AND FUTURE DIRECTIONS

Yet, despite the significant advancements in biodiesel innovation across the globe, Nigeria has a very underdeveloped biodiesel industry due to technical, infrastructural, and policy-related gaps. In addition, little research has been conducted on key biodiesel feedstock crops such as *Jatropha curcas*, *Pongamia pinnata*, and the castor oil plant. Moreover, little research has been conducted on the optimisation of agronomy and processes for biodiesel production. Most studies have focused on basic and simple catalysts such as alkaline catalysts, whereas more complex nanocatalysts and enzyme catalysts have not been sufficiently addressed. Similarly, little research has been conducted on microalgae biodiesel. Furthermore, few empirical studies have been conducted on engine performance for local biodiesel blends. Additionally, regarding biofuel policies, Nigeria's biofuel policy is outdated and was adopted in 2007; however, it has not been reviewed to include blending targets, quality specifications, and institutional coordination. Concerning social dimensions, opportunities for employment generation, gender engagement, and sustainability are not being maximised. By adopting the 3E framework's integrated approach to energy efficiency, economic viability, and environmental integrity, Nigeria can realise its potential to achieve a 10-15% market share for biodiesel fuels by 2035 and become a leader in the Net Zero ambition for 2060.

7.0 Conclusion

The review emphasises that not only is there feasibility in the development of sustainable biodiesel in Nigeria on a technical level, but there are also environmental and socio-economic benefits to be gained. To ensure that the full potential of this industry is realised, systemic changes are needed in this field. By learning from the best practices worldwide, Nigeria has tremendous opportunities to make the best use of the available feedstock, waste, and human capital in the development of this industry. In this regard, certain issues need to be addressed in the short term to achieve this vision. First and foremost, a national framework for the collection of feedstock in Nigeria needs to be developed. Additionally, there is a need to upgrade the technology used in the production of biodiesel by employing the latest catalysts and techniques. Thirdly, building special facilities for testing and evaluating engine performance is likely to assist in validating the quality and suitability of biodiesel for use in Nigeria. Finally, the government needs to formulate market and fiscal policies that can encourage and support the use of biodiesel. This can be achieved through tax reliefs and other public-private partnerships that reward verified savings and encourage investment in carbon reduction. With its steadfast commitment to this cause and through its policy direction and the active participation of all relevant actors, such as research institutions, industry players, farmers, and policymakers, biodiesel is likely to become a cornerstone of Nigeria's transition to a clean, inclusive, and self-reliant energy future.

References

1. Adejumo, O., Sodiq, A., & Yusuf, A. (2024). Genetic improvement and agronomic optimization of *Jatropha curcas* for biodiesel production in sub-Saharan Africa. *Renewable Energy*, 235, 1204–1215. <https://doi.org/10.1016/j.renene.2024.03.081>
2. Adewale, F. A., & Mustapha, H. I. (2021). Food security and biofuel production in Nigeria: Challenges and policy options. *Energy Policy Research*, 8(2), 88–99. <https://doi.org/10.1080/23815639.2021.1914230>
3. Ávila, G., Szklo, A., & Lucena, A. (2024). Life-cycle GHG emissions of biodiesel pathways in Latin America. *Journal of Cleaner Production*, 443, 140792. <https://doi.org/10.1016/j.jclepro.2024.140792>
4. Anyaoha, K. E., Sakrabani, R., Patchigolla, K., & Mouazen, A. M. (2019). Critical evaluation of oil palm fresh fruit bunch solid wastes and bioenergy potential. *Renewable and Sustainable Energy Reviews*, 107, 518–529. <https://doi.org/10.1016/j.rser.2019.03.022>
5. Barron's. (2024, June 4). Waste oil prices surge as renewable diesel demand outpaces supply. <https://www.barrons.com>

6. Bhardwaj, A., Sharma, A., & Sahoo, P. K. (2021). Waste cooking oil biodiesel: Process optimization, engine performance and emission characteristics. *Fuel*, 293, 120472. <https://doi.org/10.1016/j.fuel.2021.120472>
7. Boshnak, H. (2023). The impact of capital structure on firm performance: Evidence from Saudi-listed firms. *International Journal of Disclosure and Governance*, 20(1), 15–26. <https://doi.org/10.1057/s41310-022-00164-3>
8. Casson, A., Obidzinski, K., & Tanaka, Y. (2019). Land governance and sustainable palm oil expansion in developing countries. *World Development*, 123, 104608. <https://doi.org/10.1016/j.worlddev.2019.104608>
9. Chimezie, C. E. (2022). Techno-economic assessment of biodiesel from waste oils in West Africa. *Biofuels*, 13(7), 857–869. <https://doi.org/10.1080/17597269.2021.1912345>
10. Chisti, Y. (2020). Biodiesel from microalgae: Review of processes and sustainability. *Energy Reports*, 6, 218–232. <https://doi.org/10.1016/j.egyvr.2019.12.002>
11. Cohen, R. E. (2021). Compulsory service, citizenship, and the modern state. *Armed Forces & Society*, 47(2), 267–285. <https://doi.org/10.1177/0095327X20973224>
12. Dinneya-Onuoha, A. I. (2025). Revisiting Nigeria’s biofuel policy: Governance gaps and pathways to implementation. *Energy Policy*, 191, 114890. <https://doi.org/10.1016/j.enpol.2025.114890>
13. Djatmika, M., Paminto, A., & Wulandari, R. S. (2023). Social safeguards and livelihood inclusion in biodiesel programs of Southeast Asia. *Sustainability*, 15(11), 8802. <https://doi.org/10.3390/su15118802>
14. Energy Commission of Nigeria. (2024). Renewable Energy Master Plan (Revised Edition). Abuja. Eni S.p.A. (2023). Hydrotreated vegetable oil (HVO) refinery operations report. <https://www.eni.com>
15. European Commission. (2023). Renewable Energy Directive (RED II) implementation status. Brussels: EC Energy Directorate.
16. EPA (U.S. Environmental Protection Agency). (2024). Renewable Fuel Standard (RFS) Annual Data. <https://www.epa.gov>
17. EPE Brasil (Empresa de Pesquisa Energética). (2024). RenovaBio 2023 progress report. Brasília: Ministry of Mines and Energy. <https://www.epe.gov.br>
18. FAO. (2023). Bioenergy and food security: Country assessments and policy lessons. Rome: Food and Agriculture Organization. <https://www.fao.org/bioenergy>
19. FAO. (2024). Bioenergy for Sustainable Development in Africa: Policy Toolkit. Rome.
20. Federal Ministry of Environment, Nigeria. (2023). National Climate Change Policy and Response Strategy (2023 update). Abuja.
21. Finestone, A. S., Milgrom, C., Yanovich, R., Evans, R. A., Constantini, N., & Moran, D. S. (2019). Overuse injuries in the military: A review of causes, prevention, and rehabilitation. *Military Medicine*, 184(1–2), e83–e90. <https://doi.org/10.1093/milmed/usy300>
22. Gaide, L. (2024). Biodiesel governance, land use, and environmental integrity: Lessons from the EU RED II. *Renewable Energy Law Review*, 15(2), 119–138. <https://doi.org/10.4337/relr.2024.02.006>

23. Gomes, R. A. M. (2025). Hydrotreated vegetable oil (HVO) economics and sustainability pathways in developing markets. *Fuel Processing Technology*, 259, 108684. <https://doi.org/10.1016/j.fuproc.2025.108684>
24. Han, J., Choi, S. H., & Kim, D. H. (2022). Advances in heterogeneous catalysis for sustainable biodiesel production. *Catalysts*, 12(4), 454. <https://doi.org/10.3390/catal12040454>
25. Hanafy, M. E. (2025). Land-use change and carbon accounting in global biodiesel supply chains. *Environmental Research Letters*, 20(3), 035006. <https://doi.org/10.1088/1748-9326/ad46e2>
26. ICCT (International Council on Clean Transportation). (2021). Practical policy design for sustainable biodiesel: Lessons from global experience. Washington, DC. <https://theicct.org>
27. ICCT. (2024). Outlook for waste-based biodiesel and renewable diesel feedstocks 2024–2030. Washington, DC. <https://theicct.org>
28. IPCC. (2023). AR6 Synthesis Report: Climate Change 2023. Geneva: Intergovernmental Panel on Climate Change. IEA (International Energy Agency). (2024). Renewables 2024: Analysis and forecast to 2029. Paris: OECD/IEA. <https://www.iea.org/reports/renewables-2024>
29. Igwebuike, C. M. (2023). Biodiesel: Analysis of production, efficiency, economics and sustainability in Nigeria. *Clean Technologies & Recycling*, 3(2), 92–106. <https://doi.org/10.3934/ctr.2023006>
30. IRENA. (2025). Renewable Energy and Jobs Annual Review 2025. Abu Dhabi.
31. IRENA (International Renewable Energy Agency). (2022). Global biofuels outlook: Technology and policy drivers 2022–2030. Abu Dhabi: IRENA. <https://www.irena.org>
32. IRENA. (2023). Renewable energy statistics and trends 2023. Abu Dhabi: IRENA. <https://www.irena.org/publications>
33. IEA. (2022). Net Zero by 2050: Roadmap for the Global Energy Sector (2022 update). <https://www.iea.org/reports/net-zero-by-2050>
34. IRENA. (2024). Global Hydrogen and Biofuels Outlook 2024. <https://www.irena.org>
35. Jensen, M. C., & Meckling, W. H. (2020 reprint). Theory of the firm: Managerial behavior, agency costs and ownership structure. *Journal of Financial Economics*, 3(4), 305–360.
36. Khan, M. A., Idris, Z., & Ahmad, N. (2022). Palm-oil-based biodiesel in Southeast Asia: Policy evolution and environmental assessment. *Sustainability*, 14(12), 7074. <https://doi.org/10.3390/su14127074>
37. Kumar, R., Patel, M., & Singh, D. (2023). Recent developments in biodiesel production from waste and non-edible feedstocks: Process optimization and engine performance. *Renewable and Sustainable Energy Reviews*, 182, 113407. <https://doi.org/10.1016/j.rser.2023.113407>
38. NETP. (2023). Nigeria Energy Transition Plan 2023. Abuja: Federal Government of Nigeria. <https://energytransition.gov.ng>
39. Neste. (2024). Neste renewable diesel and SAF market outlook 2024. <https://www.neste.com>
40. NNPC. (2023). Statistical bulletin: Petroleum products consumption and imports 2022–2023. Abuja: Nigerian National Petroleum Company Limited.
41. NNPC. (2024). Annual Statistical Bulletin 2024: Renewable Energy Data Annex. Abuja.

42. NREL. (2025). Biodiesel process design and cost update 2025. Golden, CO.
43. NREL (National Renewable Energy Laboratory). (2024). Techno-economic analysis of renewable diesel production pathways. Golden, CO. <https://www.nrel.gov>
44. OECD. (2022). Biofuels Policy Review: Lessons for Emerging Markets. Paris: OECD Publishing.
45. Ogunkunle, O., & Ahmed, N. A. (2019). A review of global biodiesel production and policy strategies: Lessons for Nigeria. *Renewable and Sustainable Energy Reviews*, 107, 641–653. <https://doi.org/10.1016/j.rser.2019.03.004>
46. Okoro, E. E., Adebayo, A. O., & Sani, A. M. (2022). Comparative analysis of oil yield and fuel quality from *Jatropha*, *Pongamia* and *Castor* seeds cultivated in Nigeria. *Journal of Cleaner Production*, 367, 132956. <https://doi.org/10.1016/j.jclepro.2022.132956>
47. Okoro, E. E. (2024). Economic feasibility of small-scale biodiesel plants in rural Nigeria. *Energy Reports*, 10, 755–768. <https://doi.org/10.1016/j.egy.2024.03.019>
48. Okoroafor, U. C., & Igwe, C. E. (2024). Techno-economic feasibility of hybrid biodiesel production systems in Nigeria. *Energy Reports*, 10, 987–999. <https://doi.org/10.1016/j.egy.2024.03.072>
49. Opoku-Asante, K., Winful, E. C., Sharifzadeh, M., & Neubert, M. (2022). Capital structure and financial performance of firms in Ghana and Nigeria. *European Journal of Business and Management Research*, 7(1), 236–244. <https://doi.org/10.24018/ejbmr.2022.7.1.1305>
50. Paminto, A., Djatmika, M., & Susanto, D. (2022). Smallholder inclusion in Indonesia's biodiesel program: A policy review. *Energy Reports*, 8, 9992–10007. <https://doi.org/10.1016/j.egy.2022.07.076>
51. Pandey, S. (2024). Life-cycle energy and cost analysis of microalgae biodiesel systems. *Bioresource Technology Reports*, 24, 101691. <https://doi.org/10.1016/j.biteb.2024.101691>
52. Rajan, D., & Besim, M. (2024). Firms' capital structure during crises: Evidence from the United Kingdom. *Sustainability*, 16(13), 5469. <https://doi.org/10.3390/su16135469>
53. Reuters. (2025, February 18). Brazil to keep mandatory biodiesel blend at 14%, minister says. <https://www.reuters.com/business/energy/brazil-keep-mandatory-biodiesel-blend-14-minister-says-2025-02-18>
54. Sahoo, P. K., Rout, R., & Singh, A. K. (2022). Non-edible oil-based biodiesel: Technological updates and policy insights. *Fuel*, 320, 123989. <https://doi.org/10.1016/j.fuel.2022.123989>
55. Sharma, A. K. (2025). Nanocatalysts in biodiesel production: Advances and challenges. *Chemical Engineering Journal Advances*, 21, 101142. <https://doi.org/10.1016/j.ceja.2025.101142>
56. Silva, F. R. da, Santos, R. de S., Mendes, M. de L., Gongora, B., Lisboa, F. da S., & Sequinel, R. (2023). Biodiesel in Brazil: An analysis of production, consumption, and prospects in the energy transition. *Research, Society and Development*, 12(11), e43670. <https://doi.org/10.33448/rsd-v12i11.43670>
57. Singh, R., Chauhan, B. S., & Kumar, N. (2022). Performance, combustion and emission characteristics of a diesel engine fueled with biodiesel blends. *Energy Conversion and Management*, 265, 115776. <https://doi.org/10.1016/j.enconman.2022.115776>

58. Strebulaev, V. V., Shalneva, M. S., & Lviv, A. S. (2021). The relationship between capital structure and the financial performance of the company. *SHS Web of Conferences*, 91, 01002. <https://doi.org/10.1051/shsconf/20219101002>
59. Tang, P. L. (2023). Circular bioeconomy approaches in biodiesel production: Waste-to-energy integration. *Journal of Environmental Management*, 332, 117265. <https://doi.org/10.1016/j.jenvman.2023.117265>
60. Titman, M. A., Hossain, T., & Sen, K. K. (2024). Revisiting the puzzle of capital structure determinants: An empirical study based on UK firms. *Arab Gulf Journal of Scientific Research*, 42(4), 1359–1378. <https://doi.org/10.1108/AGJSR-04-2024-0142>
61. Tunagur, E. M. K., & Tunagur, M. T. (2024). Ethical controversies in modern conscription systems. *Defence and Peace Economics*, 35(1), 55–72. <https://doi.org/10.1080/10242694.2024.2301721>
62. UNEP. (2024). Bioenergy sustainability indicators report. Nairobi: United Nations Environment Programme.
63. UNIDO. (2024). Industrial biofuel value-chain development in Africa. Vienna.
64. Ullah, S., Pinglu, C., Zaman, M., & Hashmi, S. H. (2020). The nexus between capital structure, firm-specific factors, macroeconomic factors and financial performance in the textile sector of Pakistan. *Heliyon*, 6(8), e04741. <https://doi.org/10.1016/j.heliyon.2020.e04741>
65. US DOE. (2023). Bioenergy Technologies Office Multi-Year Program Plan. Washington, DC.
66. Wirawan, W. B. (2024). Indonesia's B35 biodiesel program: Implementation lessons and sustainability trade-offs. *Energy Policy*, 189, 114855. <https://doi.org/10.1016/j.enpol.2024.114855>
67. World Bank. (2023). Nigeria Development Update: Seizing the Opportunity for Renewable Energy. <https://www.worldbank.org/nigeria>
68. Zhou, L., & Li, M. (2024). Comparative techno-economic assessment of biodiesel and renewable diesel pathways. *Renewable Energy*, 228, 116487. <https://doi.org/10.1016/j.renene.2024.02.088>

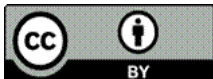

© 2026 by the authors. Submitted for possible open access publication under the terms and conditions of the Creative Commons Attribution (CC BY) license (<https://creativecommons.org/licenses/by-nc-sa/4.0/>).